



Material: Acero

Peso: 9,6 kg

Acabado: Pintado epoxi al

horno Embalaje: Caja de carton

Tornilleria no suministrada

Capacidad: 50L

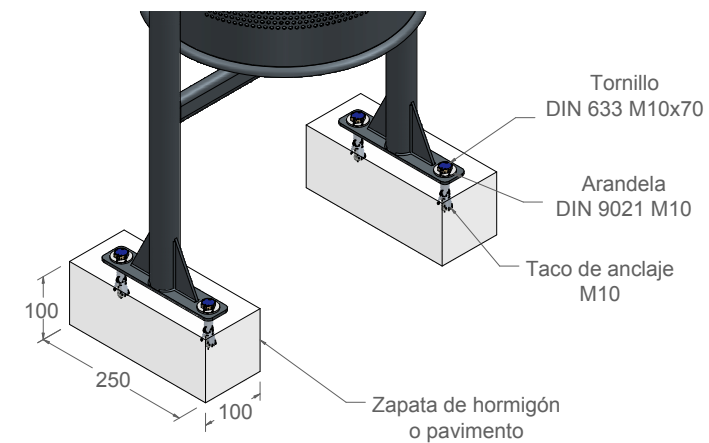
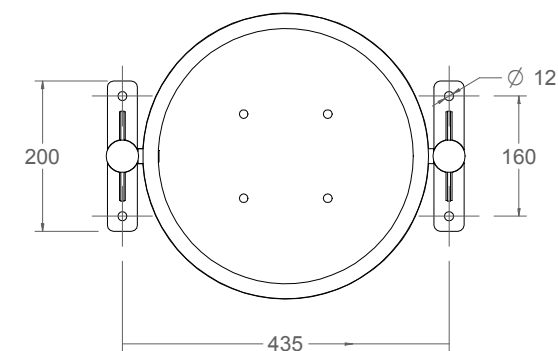
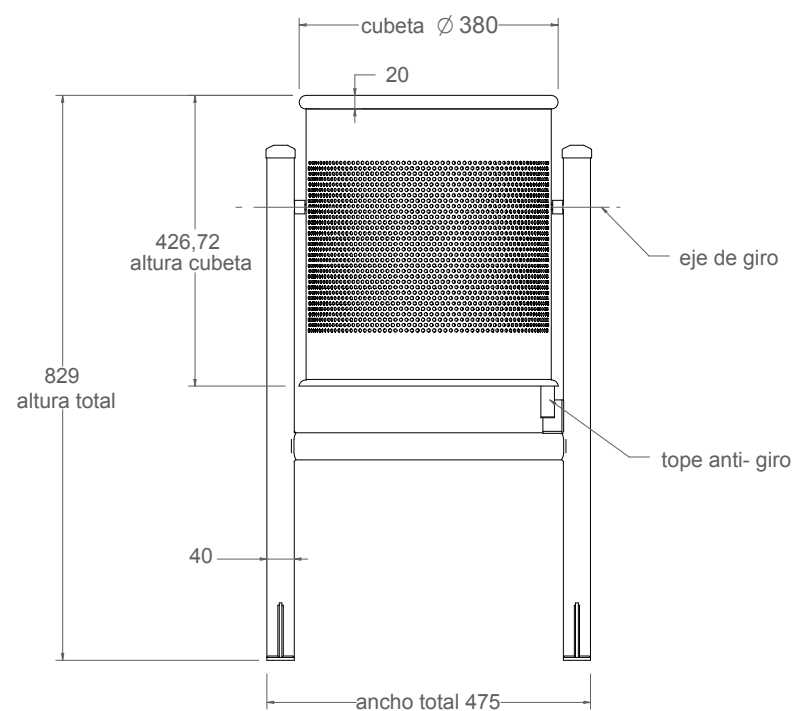

[+ PRODUCTOS HAZ CLICK](#) 